

# Power Factor Correction Module

<b>85-264Vrms*</b> Input Voltage	<b>47 - 63Hz / 360 - 800Hz</b> Input Frequency	<b>390Vdc</b> Output Voltage	<b>700W</b> Output Power	<b>≥0.99</b> Power Factor	<b>Up to 96%</b> Full Load Efficiency
-------------------------------------	---	---------------------------------	-----------------------------	------------------------------	--

The PFCQor<sup>®</sup> Power Factor Correction module is an essential building block of an AC-DC power supply. Used in conjunction with a hold-up capacitor, SynQor's high efficiency DC-DC converters and SynQor's AC line filter, the PFCQor will draw a nearly perfect sinusoidal current (PF>0.99) from a single phase AC input. The PFCQor is capable of being paralleled for higher power levels. The module is supplied completely encased to provide protection from the harsh environments seen in many industrial and transportation environments.



\* The label shows a narrower input voltage range to be consistent with labeling requirements of IEC60950-1, Section 1.7

## Operational Features

- Universal input voltage range: 85-264Vrms
- Universal input frequency range: 47 - 63Hz / 360 - 800Hz
- Up to 700W output power
- ≥0.99 Power Factor
- High efficiency: >96% (230Vrms)  
>94% (115Vrms)
- Internal inrush current limit
- Auxiliary 10V bias supply
- Can be paralleled with current sharing
- Compatible with SynQor DC-DC converters & AC line filters

## Mechanical Features

- Industry standard half-brick pin-out
- Size: 2.386" x 2.486" x 0.512" (60.6 x 63.1 x 13.0 mm)
- Total weight: 4.9 oz (139 g)
- Flanged baseplate version available

## Safety Features

- Input/Output to baseplate isolation 2150Vdc
- UL 60950-1
- CAN/CSA-C22.2 No. 60950-1
- EN60950-1
- CE Marked

## Control Features

- PFC Enable
- Load Enable (also: Power Out Good signal)
- AC Power Good Signal
- Clock synchronization
- Output current monitor / Active current sharing

## Protection Features

- Input current limit and auto-recovery short circuit protection
- Auto-recovery input under/over-voltage protection
- Auto-recovery output over-voltage protection
- Auto-recovery thermal shutdown

## Compliance Features

- (With SynQor AC Line Filter)
- EN55011 and EN55022, FCC PART 15
  - EN61000-3-2

## Contents

	Page No.
Technical Specification . . . . .	2
Standards & Qualification Testing . . . . .	7
Application Section . . . . .	8
Mechanical Diagrams . . . . .	15
Ordering Information . . . . .	17

## Typical Application of the PFC Module

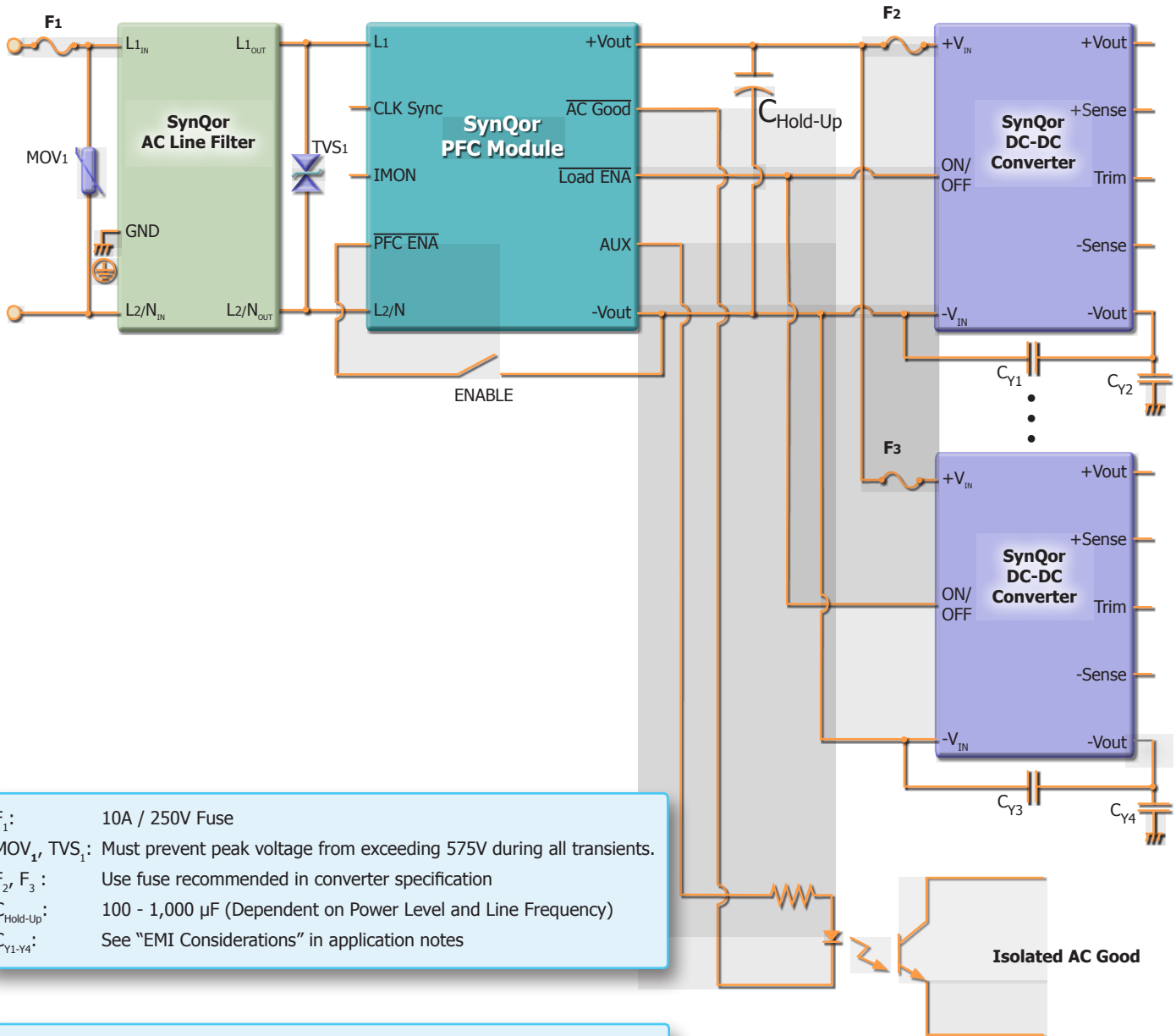

- $F_1$ : 10A / 250V Fuse
- $MOV_1, TVS_1$ : Must prevent peak voltage from exceeding 575V during all transients.
- $F_2, F_3$ : Use fuse recommended in converter specification
- $C_{Hold-Up}$ : 100 - 1,000  $\mu$ F (Dependent on Power Level and Line Frequency)
- $C_{Y1-Y4}$ : See "EMI Considerations" in application notes

### Suggested Parts:

- $F_1$ : 250VAC, 10A; Littelfuse 0216010.MXEP
- $MOV_1$ : 300VAC, 60J; EPCOS S10K300E2
- $TVS_1$ : 400V, 3J; Use two VISHAY 1.5KE200CA devices connected in series
- $C_{Hold-Up}$ : 450V, 330 $\mu$ F; EPCOS B43508B5337M
- $C_{Y1}, C_{Y3}$ : 3.3nF, 500VAC; Vishay VY1332M59Y5UQ6TV0
- $C_{Y2}, C_{Y4}$ : 10nF, 300VAC; Vishay VY2103M63Y5US63V7

Figure A: Typical Application of the PFCQor module to create a multiple-ouput AC-DC Power Supply

## PFCU390HPx07 Electrical Characteristics

Operating conditions of 115Vrms, 60Hz input, 700W output, 390uF bulk capacitance, and baseplate temperature = 25°C unless otherwise noted; full operating baseplate temperature range is -40 °C to +100 °C with appropriate power derating. Specifications subject to change without notice.

Parameter	Min.	Typ.	Max.	Units	Notes & Conditions
<b>ABSOLUTE MAXIMUM RATINGS</b>					
Input Voltage (L1 to L2/N)					
Operating					
Continuous			264	Vrms	
			375	Vpk	
Transient (≤100ms)			290	Vrms	
			410	Vpk	
Non-Operating			400	Vrms	
			575	Vpk	
Isolation Voltage (Input / Output to Baseplate)			2150	Vdc	
Operating Temperature	-40		100	°C	Baseplate temperature
Storage Temperature	-45		125	°C	
Voltage at AC GOOD and LOAD ENA pins	-0.3		16	V	Relative to Vout- pin
Current drawn from AUX pin	0		10	mADC	
Voltage at PFC enable pin	-2		575	V	Relative to Vout- pin
Voltage at CLK SYNC In	-2		5.5	V	Relative to Vout- pin
<b>INPUT CHARACTERISTICS (L1 to L2/N)</b>					
Operating Input Voltage Range					
AC Input Continuous	85		264	Vrms	
AC Input 100ms Transient	40		290	Vrms	Available output power reduced when <85 Vrms >1s Duration
Input Under-Voltage Lockout		30		Vrms	
Operating Input Frequency					
50/60Hz	47		63	Hz	
400Hz	360		800	Hz	
Power Factor of AC Input Current		0.99			50/60Hz
		0.97			400Hz, min 400W output
Total Harmonic Distortion of AC Input Current		3		%	
Inrush of AC Input Current					
			10	A	
			25	A	230V, 400Hz
Enabled AC Input Current (no load)		50	80	mArms	
Disabled AC Input Current		30	50	mArms	
Maximum Input Power			775	W	Vin >85Vrms
Maximum Input Current			9.5	Arms	85 VAC in
<b>OUTPUT CHARACTERISTICS</b>					
Output Voltage Set Point	385	390	395	Vdc	Vin <240 Vrms, see figure 10
Output Voltage Regulation					
Over Line			±0.3	%	Vin <240 Vrms, see figure 10
Over Load			±2	%	
Over Temperature			±1.5	%	
Total Output Voltage Range:					
Input Voltage within Continuous Range	380		395	Vdc	Vin <240 Vrms, see figure 10
Input Voltage within Transient Range	365		430	V	
Input Voltage Brownout/Dropout	200		395	V	See application section
Output Voltage Ripple and Noise					
Peak-to-Peak			10	V	60Hz, see Note 1
RMS			4	V	Dependent on Hold-up capacitor
Operating Output Current Range	0		1.8	A	
Output Over-Voltage Shutdown Threshold	420		460	V	
Output (Hold-up) Capacitance	100		1,000	µF	See Note 2
Output Common-Mode Capacitance			20	nF	See "EMI Considerations" in application notes
<b>Efficiency</b>					
50% Load		94		%	See Figure 1 for efficiency curve
100% Load		95		%	See Figure 1 for efficiency curve

Note 1: 300 µF electrolytic hold-up capacitor having a typical ESR of 0.5Ω. More capacitance/Lower ESR will reduce the line frequency ripple.

Note 2: The PFCQor is able to operate with a minimum of 100uF of hold-up capacitance but SynQor recommends at least 330uF if the power system will be required to conform to lightning surge standards.

This is because the PFCQor relies on the hold-up capacitor to absorb the energy from a lightning surge.

## PFCU390HPx07 Electrical Characteristics (continued)

Operating conditions of 115Vrms, 60Hz input, 700W output, 390uF bulk capacitance, and baseplate temperature = 25°C unless otherwise noted; full operating baseplate temperature range is -40 °C to +100 °C with appropriate power derating. Specifications subject to change without notice.

Parameter	Min.	Typ.	Max.	Units	Notes & Conditions
<b>DYNAMIC CHARACTERISTICS</b>					
Turn-On Transient					
Start-up Inhibit Time		10		ms	
Turn-On Time		2		s	
Output Voltage Overshoot			0	%	
<b>ISOLATION CHARACTERISTICS (Input/output to baseplate)</b>					
Isolation Voltage			2150	V	
Isolation Resistance		100		MΩ	
Isolation Capacitance		100		pF	
<b>TEMPERATURE LIMITS FOR POWER DERATING CURVES</b>					
Semiconductor Junction Temperature			125	°C	
Board Temperature			125	°C	
Transformer Temperature			125	°C	
Maximum Baseplate Temperature, Tb			100	°C	
<b>FEATURE CHARACTERISTICS</b>					
Output Precharge					
Output Current		100		mA	
Output Short-Circuit Withstand			indefinite	s	
Free Running Switching Frequency		200		kHz	Each of 4 interleaved phases
Clock Synchronization Input (CLK SYNC)					
Frequency Range	150		250	kHz	
Logic Level High	2			V	
Logic Level Low			0.8	V	
Duty Cycle	20		80	%	
PFC Enable (PFC ENA)				V	
Off-State Voltage	2				
On-State Voltage			0.8		
Internal Pull-Up Voltage		5		Vpk	
Internal Pull-Up Resistance		10		kΩ	
AC Good (AC GOOD)					
AC Input Voltage for AC Good	119		375	Vpk	
AC Good State	0		0.4	V	
AC Not Good State			15	V	Open Collector
Maximum Sink Current			300	mA	
Load Enable					
(also: Output Power Good) (LOAD ENA)					
Enable (Good) State	0		0.4	V	
Disable (Not Good) State			15	V	Open Collector
Maximum Sink Current			300	mA	
Output Voltage for Load Enable (Good) State					
Rising / Startup		360		V	
Falling / Shutdown		200		V	
Over-Temperature Trip Point		130		°C	At internal PCB
Auxiliary Bias Supply					
Voltage Range (≤3 mA Load)	7		12	V	
Maximum Source Current			10	mA DC	
Equivalent Series Resistance		1		kΩ	
<b>RELIABILITY CHARACTERISTICS</b>					
Calculated MTBF (Telcordia) TR-NWT-000332		2.5		10 <sup>6</sup> Hrs.	Tb = 70°C
Calculated MTBF (MIL-217) MIL-HDBK-217F		2		10 <sup>6</sup> Hrs.	Tb = 70°C

# SynQor®

## Technical Specification

**PFCU390HPx07**

**Input: 100-240Vrms**

**Output: 390Vdc**

**Power: Up to 700W**

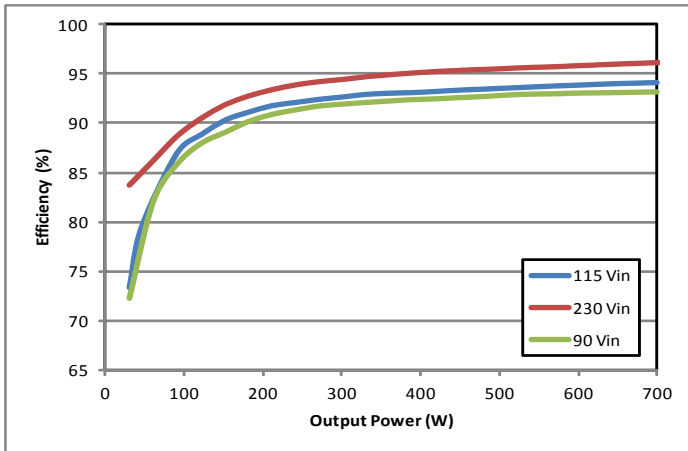

Figure 1: Efficiency at nominal output voltage vs. load power for 90Vrms, 115Vrms and 230Vrms (60Hz) input voltage at  $T_b = 25^\circ\text{C}$ .

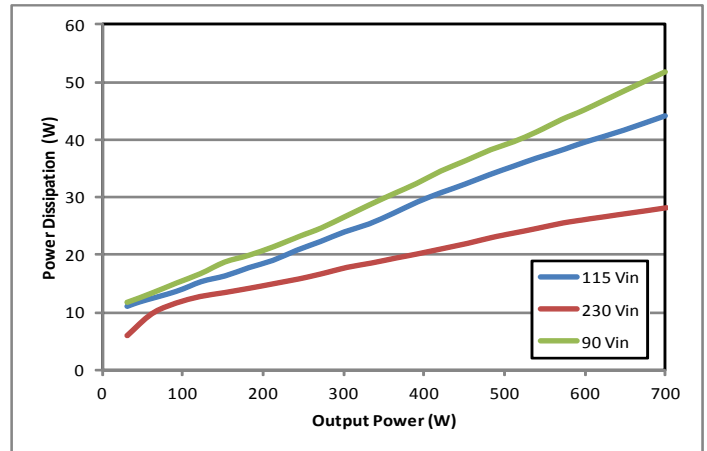

Figure 2: Power dissipation at nominal output voltage vs. load power for 90Vrms, 115Vrms and 230Vrms (60Hz) input voltage at  $T_b = 25^\circ\text{C}$ .

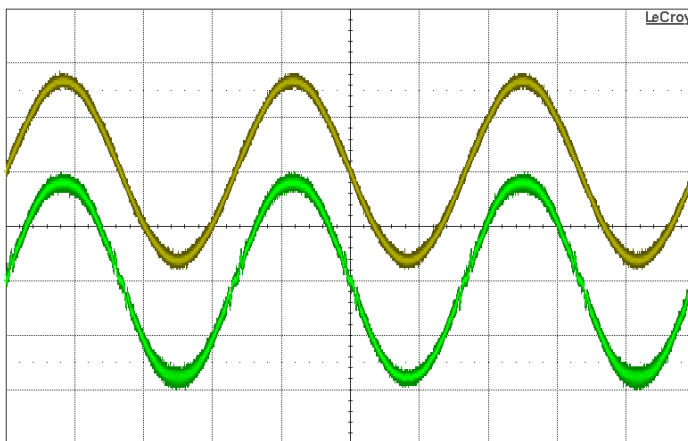

Figure 3: Typical Input Voltage and Current waveforms at full rated power (115Vrms, 60Hz) Yellow:  $V_{in}$  (100V/div), Green:  $I_{in}$  (5A/div), Timebase: (5ms/div).

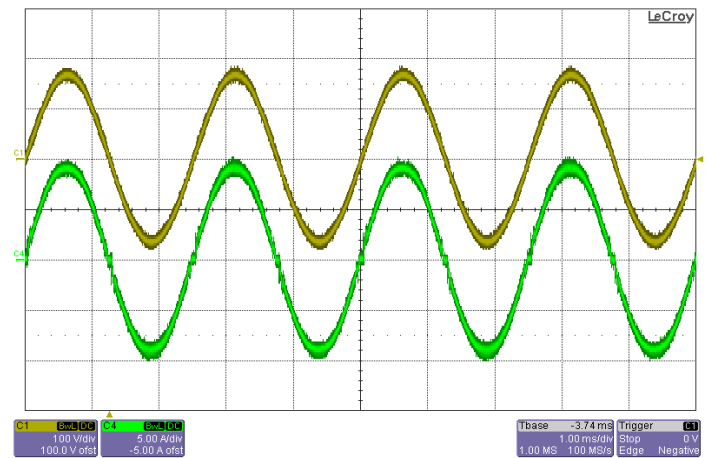

Figure 4: Typical Input Voltage and Current waveforms at full rated power (115Vrms, 400Hz). Yellow:  $V_{in}$  (100V/div), Green:  $I_{in}$  (5A/div), Timebase: (1ms/div).

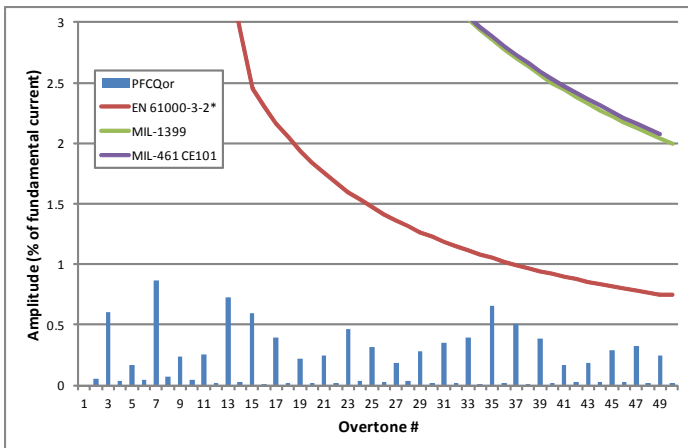

Figure 5: Frequency spectrum of input current at full rated power (115Vrms, 60Hz).

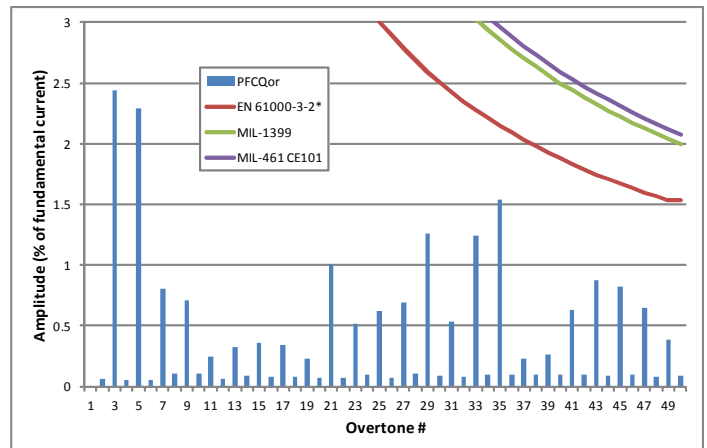

Figure 6: Frequency spectrum of input current at full rated power (230Vrms, 60Hz).



# SynQor®

## Technical Specification

**PFCU390HPx07**  
**Input: 100-240Vrms**  
**Output: 390Vdc**  
**Power: Up to 700W**

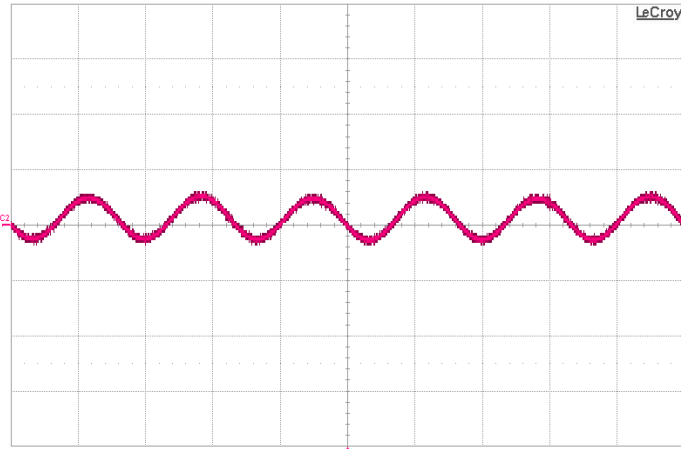

Figure 7: Output voltage with 500µF Hold-up capacitor at full rated power (115VAC, 60Hz) Red: Vout (10V/div), Timebase: (5ms/div)

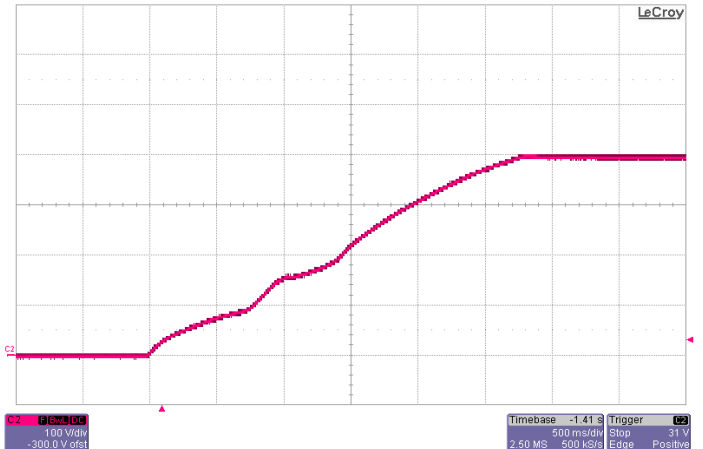

Figure 8: Output voltage startup waveform (115VAC, 60Hz) Red: (100V/div), Timebase: (500ms/div)

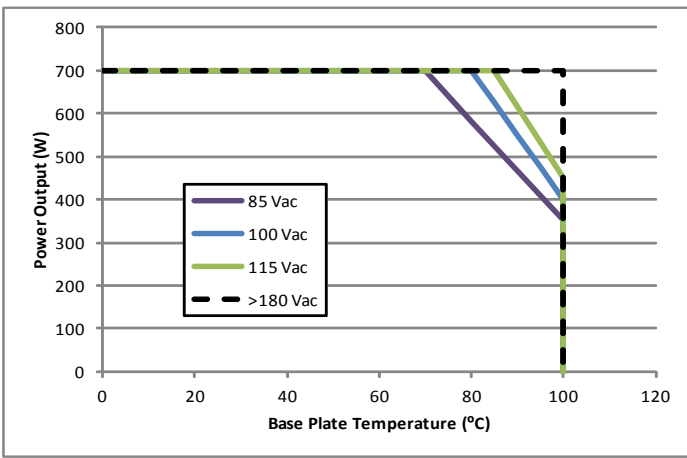

Figure 9: Output power vs. baseplate temperature derating curve

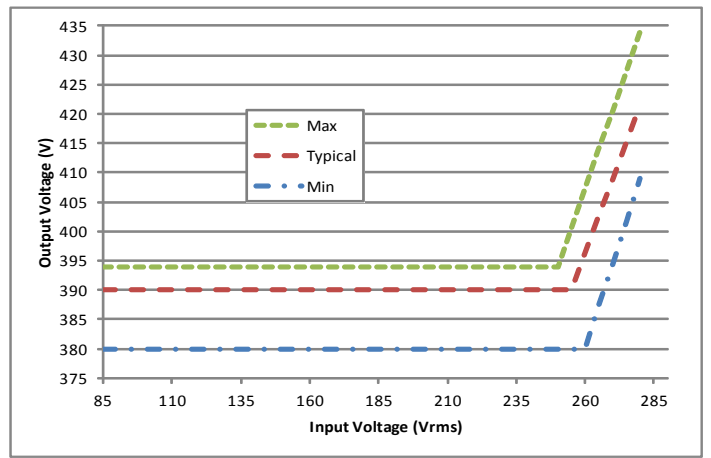

Figure 10: DC output voltage range vs. input voltage

## Standards Compliance, Qualification Testing & EMC Characteristic

Parameter	Notes & Conditions
-----------	--------------------

### STANDARDS COMPLIANCE

UL 60950-1	Basic Insulation to Baseplate
CAN/CSA-C22.2 No. 60950-1	
EN60950-1	
CE Marked	

Note: An external input fuse must always be used to meet these safety requirements. Contact SynQor for official safety certificates on new releases or download from the SynQor website.

Parameter	# Units	Test Conditions
-----------	---------	-----------------

### QUALIFICATION TESTING

Life Test	32	95% rated Vin and load, units at derating point, 1000 hours
Vibration	5	10-55 Hz sweep, 0.060" total excursion, 1 min./sweep, 120 sweeps for 3 axis
Mechanical Shock	5	100g minimum, 2 drops in x,y and z axis
Temperature Cycling	10	-40 °C to 100 °C, unit temp. ramp 15 °C/min., 500 cycles
Power/Thermal Cycling	5	Toperating = min to max, Vin = min to max, full load, 100 cycles
Design Marginality	5	Tmin-10 °C to Tmax+10 °C, 5 °C steps, Vin = min to max, 0-105% load
Humidity	5	85 °C, 95% RH, 1000 hours, continuous Vin applied except 5 min/day
Solderability	15 pins	MIL-STD-883, method 2003

### EMC CHARACTERISTICS (With SynQor AC Line Filter)

Conducted emissions	EN55011 and EN55022, FCC PART 15
Line frequency harmonics	EN61000-3-2

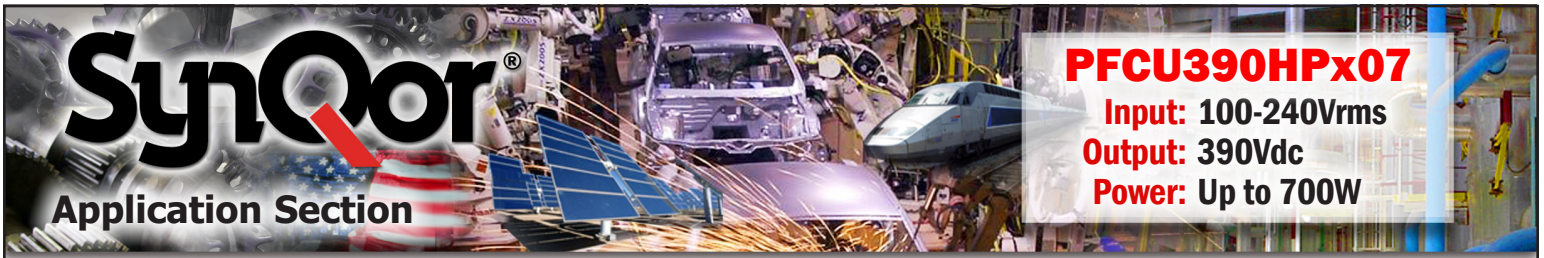

## BASIC OPERATION AND FEATURES

The PFCQ<sub>or</sub> power factor correction module is an essential building block of an overall high power AC-DC power supply. As shown in Fig. A, a typical power supply would be comprised of a SynQ<sub>or</sub> AC Line Filter, a SynQ<sub>or</sub> PFCQ<sub>or</sub> module, an energy storage hold-up capacitor and one or more SynQ<sub>or</sub> DC-DC converters, depending on how many output voltages are required. Fuses are needed in various places to meet safety requirements.

The primary purpose of the PFCQ<sub>or</sub> is to shape the input current that is drawn from a single-phase sinusoidal AC source into a nearly perfect sinusoidal waveform so that the AC-DC power supply will present a very high power factor load ( $PF > 0.99$ ) to this source. In doing this wave-shaping, the PFCQ<sub>or</sub> ensures that the harmonic components of the AC current waveform are well below the levels called for in EN61000-3-2. The total harmonic distortion of the AC current waveform is less than 8%.

The PFCQ<sub>or</sub> accomplishes its wave-shaping task by first rectifying the filtered AC source voltage, and then processing the input power through a non-isolated, high-efficiency, high-frequency “boost converter” that both gives the input AC current its sinusoidal shape and provides a regulated DC voltage across the hold-up capacitor.

The hold-up capacitor handles the cyclic imbalance between the flow of energy drawn from the AC source and the flow of energy delivered to the DC-DC converters. This energy imbalance has a cyclic frequency twice that of the AC source voltage (e.g. 120Hz for a 60Hz input). This relatively low frequency makes the hold-up capacitor relatively large. Another purpose of the hold-up capacitor is to be a source of energy so that the DC-DC converters can continue to deliver load power during a temporary brownout or dropout of the AC source. A typical power supply will have sufficient hold-up capacitor to give a “hold-up time” in the 20ms range, but longer times can be achieved with yet more hold-up capacitance.

Besides shaping the AC current waveform, the PFCQ<sub>or</sub> performs several other important functions. At start-up it controls the level of inrush current drawn from the AC source to charge the hold-up capacitor. It limits the DC current that can be drawn from its output and it will shut-down if a short circuit appears across the output. It will also shut-down if the AC input voltage is out of its range (either too high or too low) for too long, or if the temperature of the module is too high.

In addition, the PFCQ<sub>or</sub> has several input and output control signals that include PFC\_ENABLE, LOAD\_ENABLE, (which doubles as a POWER\_OUT\_GOOD signal), AC\_GOOD, CLOCK SYNCHRONIZATION, and OUTPUT CURRENT MONITOR. All of these signals are described in more detail below. There is also an auxiliary bias supply that can be used to power a low power control circuit at the output of the PFCQ<sub>or</sub>.

## STARTUP SEQUENCE

When the AC source voltage is first applied, regardless of whether the PFCQ<sub>or</sub> is enabled or disabled through its PFC\_ENABLE pin, the PFCQ<sub>or</sub> will pre-charge the output hold-up capacitor with a current limited to approximately 100mA. This pre-charging continues until the output voltage is within approximately 10V of the peak voltage of the AC source. If, at this time, the PFC\_ENABLE input is logically high, and the PFCQ<sub>or</sub> is therefore disabled, the PFCQ<sub>or</sub> will remain in this pre-charged state indefinitely.

**NOTE:** During both this pre-charging time and for whatever time afterwards that the PFCQ<sub>or</sub> remains disabled it is essential that all the load converters connected to the output of the PFCQ<sub>or</sub> be disabled so that the total load current seen by the PFCQ<sub>or</sub> is only a small fraction of the 100mA charging current. To help facilitate this requirement, the PFCQ<sub>or</sub>'s LOAD\_ENABLE output can be used to disable the load converters.

When the PFC\_ENABLE input pin is pulled low, and after the pre-charging is completed if it is not already, the boost converter within the PFCQ<sub>or</sub> will start operating and the PFCQ<sub>or</sub>'s output voltage will be increased to its nominal regulated value.

After this regulated voltage level is achieved, the PFCQ<sub>or</sub> will provide a logical low signal on its LOAD\_ENABLE output pin. This signal should be used to enable the load converters so that they can begin to draw power from the PFCQ<sub>or</sub>.

If the PFC\_ENABLE input is de-asserted (pulled high or allowed to float), the boost converter in the PFCQ<sub>or</sub> will shut down and the LOAD\_ENABLE output pin will return to a logic high. This will then disable the load converters.

**NOTE:** The voltage across the hold-up capacitor will remain in a charged state after the PFCQ<sub>or</sub> is disabled as long as the AC source voltage is present.

## BROWNOUT/DROPOUT SEQUENCE

If the AC source voltage falls below the PFCQor's specified continuous minimum input voltage, the **AC\_Good** output will de-assert (it will become a logic high), although the PFCQor will continue to operate as described below. This **AC\_Good** output signal can be used as a warning signal to permit a graceful shutdown of the load after some period of time that depends on the size of the hold-up capacitor.

If the AC source voltage is present but it is below its continuous minimum input voltage limit, the PFCQor will still draw whatever power it can (within its current limits) from the AC source. This power may not be enough for the total load power, in which case the hold-up capacitor will provide the balance of the power. The voltage across the hold-up capacitor will therefore drop as it discharges.

If the AC source voltage drops below its specified transient minimum input voltage limit, the PFCQor's boost converter will shut down and no longer deliver power to the output. Under this condition, all of the load power will be drawn from the hold-up capacitor.

If and when the voltage across the hold-up capacitor drops below its specified minimum limit, the **LOAD\_ENABLE** output will be de-asserted to a logic high. Besides disabling the load converters, this condition will cause the PFCQor to return to the beginning of the **STARTUP SEQUENCE** described above.

**NOTE:** Regardless of what happens to the PFCQor's output voltage under a brownout or dropout condition, if the AC source voltage drops below its rated under-voltage value for 1 second or more, the PFCQor will shut down.

If, however, the voltage across the hold-up capacitor does not drop below its specified minimum limit before the AC source voltage returns to within its continuous operating range (and it hasn't been absent for more than 1 second), the PFCQor will automatically re-establish its power flow. The hold-up capacitor will be recharged immediately to the peak of the AC source voltage (if it has fallen below this value) and to its nominal regulated voltage level within a few cycles of the AC source waveform.

**NOTE:** During the first phase where the hold-up capacitor is recharged (if it this phase exists) there will be an inrush current drawn from the AC source that depends on the details of how quickly the AC source voltage returns to its normal operating condition.

When the AC source voltage has been within the PFCQor's specified continuous operating range for at least one cycle of the source waveform, the **AC\_Good** output will again be asserted low.

## CONTROL FEATURES

### Auxiliary Bias Power Supply (Pin 6):

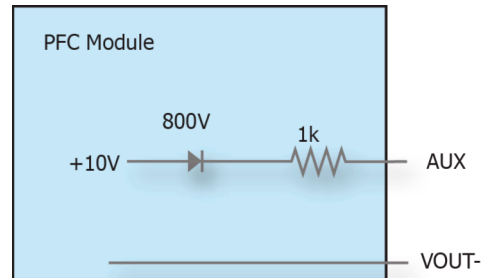

The circuit shown below is an effective model for the AUX bias power supply:

The purpose of the AUX power supply is to provide a low level of power to control circuitry at the output of the PFCQor, such as the circuits shown earlier in this section.

The AUX power supply is present and regulated whenever the PFCQor's output voltage is greater than approximately 75V. The AUX bias power supply is unspecified when PFCQor's output voltage is less than about 75V (it may, for instance, come and go as the output voltage rises on its way to 75V).

### PFC\_ENABLE (Pin 3):

The PFCQor uses the following circuit for this input logic signal:

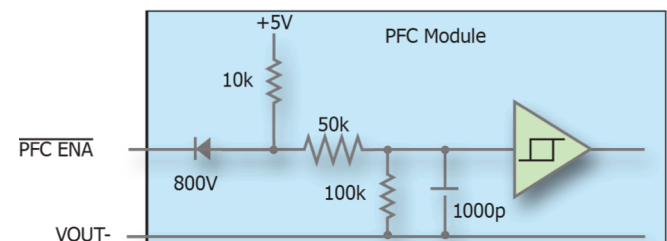

- If this input is floating or tied high the PFCQor's boost converter is disabled and the **LOAD\_ENABLE** output signal is de-asserted high.
- If this input is pulled low the PFCQor's boost is enabled after the pre-charger has charged the voltage across the hold-up capacitor to within approximately 10 volts of the peak of the AC source voltage.

## LOAD\_ENABLE (also: POWER OUT GOOD signal) (Pin 7):

The PFCQor uses the following circuit for this output logic signal:

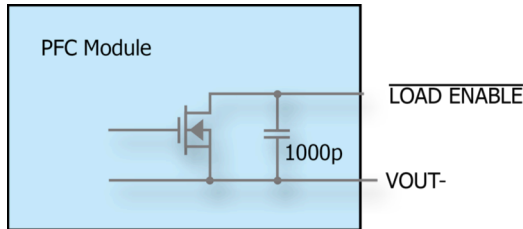

- When the **LOAD\_ENABLE** pin is internally pulled LOW the load converters are permitted to draw power from the PFCQor's output.
- When the **LOAD\_ENABLE** floats all load converters should be disabled.
- The **LOAD\_ENABLE** can be tied directly to the **ON/OFF** control pins of SynQor's DC-DC converters as shown in Figure A.
- For loads that are not SynQor DC-DC converters and that do not otherwise have a way to be enabled/disabled, an external power MOSFET can be used to connect and disconnect these loads from the PFCQor's output based on the status of the **LOAD\_ENABLE** signal, as shown below.

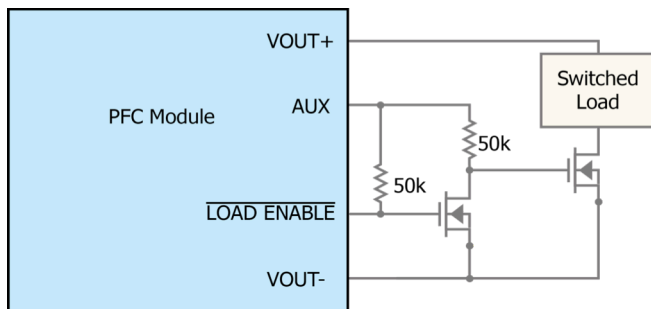

- For high-side or remotely switched loads, an optoisolator can be employed as shown below.

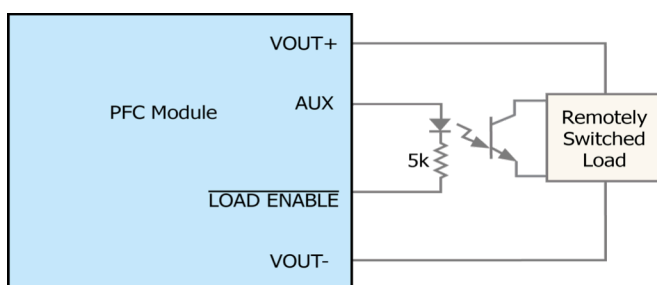

## AC\_GOOD (Pin 8):

The PFCQor uses this circuit for this output logic signal:

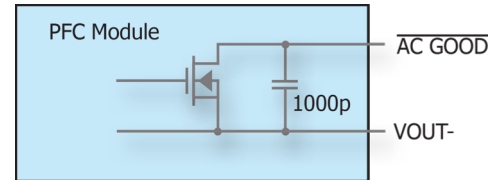

- The **AC\_GOOD** signal is internally pulled low whenever the AC source voltage is within the PFCQor's continuous operating range for at least one cycle of the source waveform, regardless of whether the PFCQor is enabled or disabled.
- When the peak of the AC source voltage is outside this continuous operating range (either too high or too low), the **AC\_GOOD** pin will float.
- The **AC\_GOOD** signal is typically used with a pullup resistor and an opto-coupler (as shown in Fig. A) to provide an isolated signal to the load that the AC source voltage is no longer within the specified continuous operating range. If this condition persists, the load power can only be delivered for the "hold-up time", and it may therefore be desirable to have the load gracefully shut down. The **AC\_GOOD** signal provides a warning for this action to be taken. When the AC source voltage returns to the specified continuous operating range, the **AC\_GOOD** signal will re-assert after a 100 ms delay.
- The **AC\_GOOD** pin is valid whenever the AUX bias supply power is valid (see above).

## Output Current Monitor (Pin B):

The PFCQor uses this circuit for this output analog signal:

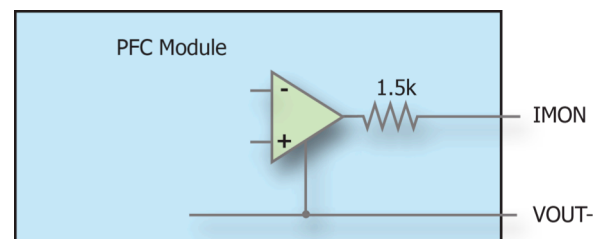

- The **IMON** signal monitors the DC average output current, line-frequency components are removed from **IMON**.
- The **IMON** output voltage is 0V at no-load and increases linearly to 2V at full-load.
- Any monitoring of this output should be accomplished with a high input impedance sensor as this pin is also used for current sharing, see below.

### Clock Synchronization (Pin 2):

The PFCQor uses the following circuit for this input logic signal.

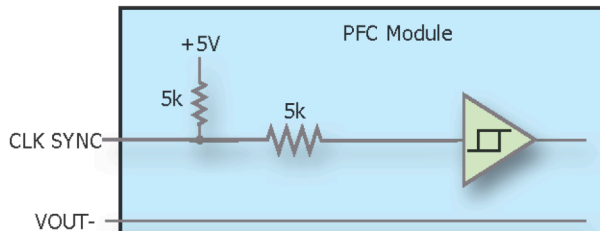

- The PFCQor performs optimally with a 200kHz switching frequency. Deviation from this frequency will result in a reduction of maximum output power. Consult factory for details.

## PROTECTION FEATURES

### Input Over- & Under-Voltage:

If the AC source voltage exceeds the maximum voltage rating the PFCQor will shut down. However, under this condition the PFCQor's pre-charge circuit will continue to deliver 100mA of current to the output whenever the AC source voltage is higher than the dc output voltage. Care must be taken to insure this condition does not allow the output voltage to rise high enough to damage the PFCQor or the load converters.

If a brownout or dropout of the AC source voltage occurs, and if it lasts long enough for the PFCQor's output voltage to drop below its specified minimum limit, the PFCQor will shut down. Furthermore, regardless of what happens to the PFCQor's output voltage, if the AC source voltage drops below its rated under-voltage value for 1 second or more, the PFCQor will shut down.

After any shutdown the PFCQor will automatically return to the beginning of the STARTUP SEQUENCE described above.

### Output Over-Voltage:

If the output voltage exceeds its specified maximum limit, the PFCQor's boost converter will shutdown. However, under this condition the PFCQor's pre-charge circuit will continue to deliver 100mA of current to the output whenever the AC source voltage is higher than the dc output voltage. Care must be taken to insure this condition does not allow the output voltage to rise high enough to damage the PFCQor or the load converters.

### Output Current Limit & Short-Circuit Shutdown:

If the PFCQor's output is overloaded such that its output current limit becomes activated, the output voltage will fall as the excess load current discharges the hold-up capacitor. The

PFCQor will continue to deliver power into this overload condition for 100 ms, after which the unit will shut down and automatically return to the beginning of the STARTUP SEQUENCE described above. If at any point the output voltage falls below the peak of the AC source voltage, the PFCQor will immediately shut down and return to the STARTUP SEQUENCE.

### Over Temperature:

If the internal temperature of the PFCQor reaches 130°C the PFCQor will turn off its boost converter. The **LOAD\_ENABLE** output will simultaneously be de-asserted high. When the internal temperature falls below 110°C, the PFCQor will return to the beginning of the STARTUP SEQUENCE described above.

## ENERGY STORAGE HOLD-UP CAPACITOR

The hold-up capacitor performs two functions:

- It handles the cyclic imbalance between the flow of energy drawn from the AC source and the flow of energy delivered to the DC-DC converters. In doing so, the voltage across the hold-up capacitor has a ripple at a frequency twice that of the AC source voltage (e.g. 120Hz for a 60Hz input). The larger the hold-up capacitor, or the higher the frequency of the AC source, the smaller this ripple will be.
- It provides a source of energy so that the DC-DC converters can continue to deliver load power during a temporary brownout or dropout of the AC source. The larger the hold-up capacitor the longer it can provide this energy. Often it will be made large enough to allow the load to be gracefully shutdown after the AC source has been outside of its normal range for a set amount of time. A typical "hold-up time" would be in the 20 ms range for a 50/60 Hz system.

The total energy stored in a hold-up capacitor having capacitance C at any given voltage V is:

$$E = \frac{1}{2}CV^2$$

The amount of energy,  $\Delta E$ , which can be drawn from this capacitor depends on the capacitor's starting voltage,  $V_s$ , and its final voltage,  $V_f$ , where  $V_s$  is the PFCQor's nominal regulated output voltage and  $V_f$  is the PFCQor's minimum output voltage limit. This energy equals the amount of power, P, which the DC-DC converters draw from the hold-up capacitor times the length of time,  $\Delta t$ , which it takes for the hold-up capacitor's voltage to drop from  $V_s$  to  $V_f$ . This energy can be equated to the hold-up capacitance according to the following formula:

$$\Delta E = P \Delta t = \frac{1}{2}C(V_s^2 - V_f^2)$$

This formula can be rearranged to find the minimum required value for C to provide the hold-up time desired for a given power level (note: this power level P is not the load power, but rather the load power divided by efficiency of the DC-DC converters):

$$C_{min} = 2P\Delta t / (V_s^2 - V_f^2)$$

For example, if we assume P = 600W, Δt = 20ms, V<sub>s</sub> = 390V and V<sub>f</sub> = 200V, then we would want a hold-up capacitance of at least 215μF.

During the start-up sequence the PFCQor will pre-charge the hold-up capacitor with approximately 100mA of current until it has reached a voltage about 10V below the peak of the AC source voltage. The time it takes for this to occur can be calculated using the following formula:

$$t = CV/100mA$$

For example, if the AC source voltage is 230Vrms (V<sub>pk</sub> = 325V) and the hold-up capacitor is 200μF, this length of time will be approximately 0.6 seconds. The larger the hold-up capacitor, the longer it will take.

After the hold-up capacitor's voltage has reached this level, and assuming the PFCQor has been enabled, the boost converter in the PFCQor will quickly charge the hold-up capacitor to the nominal regulated output voltage level.

**NOTE:** The PFCQor is able to operate with a minimum of 100uF of hold-up capacitance, but SynQor recommends at least 330uF if the power system will be required to conform to lightning surge standards. This is because the PFCQor relies on the hold-up capacitor to absorb most of the energy from a lightning surge.

**NOTE:** Even though the PFCQor limits the inrush current drawn from the AC source during its STARTUP SEQUENCE, it will not necessarily limit this current at the end of a temporary brownout or dropout of the AC source when the hold-up capacitor's voltage has not dropped below its minimum output voltage limit. In such a condition the PFCQor will not reinitiate a STARTUP SEQUENCE and it will therefore not limit the current flowing through it. If the peak of the AC source voltage is greater than the hold-up capacitor's voltage at the end of the brownout/dropout period, there will be a large inrush current for one half-cycle as the hold-up capacitor's voltage is charged up to the peak of the AC source voltage. The larger the hold-up capacitor the larger this inrush current will be. To keep this inrush current within a reasonable limit, the maximum capacitance of the hold-up capacitor is limited as specified in the Technical Specifications table.

If it is desired to have a hold-up time longer than can be achieved with this maximum specified hold-up capacitance, then the circuit shown below can be used.

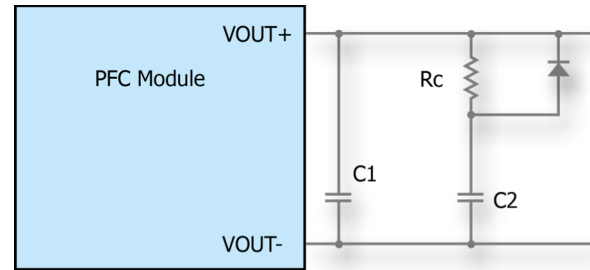

In this circuit the total hold-up capacitance is (C1 + C2), and it can be made as large as desired as long as C1 does not exceed the maximum capacitance specified in the Technical Specifications table. The resistor, Rc, in series with C2 is present to limit the current that will charge this capacitor after a temporary brownout/dropout event. Its resistance should be large enough to limit the charging current to a fraction of the PFCQor's rated output current. The diode in parallel with the resistor permits the load converters to draw whatever energy they need from C2 without being hindered by the resistor.

### Output Ripple Considerations:

The hold-up capacitor must have a ripple current rating high enough to withstand the ripple current generated on the output of the PFCQor. Ripple current amplitude is dependent only upon the total PFCQor output power, P<sub>DC</sub>, and the operating output voltage V<sub>O</sub>. It can be calculated using the following formula:

$$I_{Crms} = \frac{P_{DC}}{\sqrt{2} \cdot V_O} = \frac{P_{DC}}{551}$$

The AC line frequency, f<sub>ac</sub>, bulk capacitance, C, operating output voltage, and output power will determine the amplitude of the voltage ripple present on the output of the PFCQor. It can be calculated with:

$$V_{pk-pk} = \frac{P_{DC}}{2\pi \cdot f_{ac} \cdot C \cdot V_O}$$

$$\text{At 60 Hz: } V_{pk-pk} = \frac{P_{DC}}{1.47 \cdot 10^5 \cdot C}$$

For example, to calculate voltage and current ripple for a PFCQor with a 700W output, 500uF hold-up capacitor, and a 60Hz fundamental AC line frequency:

$$I_{Crms} = \frac{700W}{551} = 1.3A_{rms}$$

$$V_{pk-pk} = \frac{700W}{2\pi \cdot 60Hz \cdot 500 \cdot 10^{-6}F \cdot 390V} = 9.6V_{pk-pk}$$

In this case, the hold-up capacitor would require a minimum ripple current rating of 1.3A<sub>rms</sub>, and the output voltage would have a pk-pk ripple voltage of 9.6V.

## SAFETY NOTES

The output of the PFCQor is not isolated from the AC source, and it is therefore a hazardous voltage. Care must be taken to avoid contact with this voltage, as well as with the AC source voltage.

The PFCQor must have a fuse in series with its AC source. The rating for this fuse is given in the Technical Specification table. If multiple PFCQors are paralleled, there should be a fuse for each PFCQor.

## THERMAL CONSIDERATION

The maximum operating base-plate temperature,  $T_B$ , is 100 °C. Refer to the thermal derating curves to see the allowable power output for a given baseplate temperature and input voltage. A power derating curve can be calculated for any heatsink that is attached to the base-plate of the converter. It is only necessary to determine the thermal resistance,  $R_{THBA}$ , of the chosen heatsink between the base-plate and the ambient air for a given airflow rate. The following formula can then be used to determine the maximum power the converter can dissipate for a given thermal condition:

$$P_{diss}^{max} = \frac{T_B - T_A}{R_{THBA}}$$

This value of power dissipation can then be used in conjunction with the data shown in the figures to determine the maximum load power that the converter can deliver in the given thermal condition.

## AC LINE FILTER

An AC line filter is needed to attenuate the differential- and common-mode voltage and current ripples created by the PFCQor, the DC-DC converters and the load such that the system will comply with EMI requirements. The filter also provides protection for the PFCQor from high frequency transients in the AC source voltage. SynQor has a family of AC line filters that will provide these functions. It is recommended that a metal-oxide varistor (MOV) be placed from line-to-line on the input of the filter, and a TVS diode be placed from line-to-line on the output of the filter in order to keep the PFCQor input voltage from exceeding 575V during all transients. See Figure A for suggested parts. If a non-SynQor AC line filter is used, the use of an MOV on the input and a TVS diode on the output of the filter is still recommended.

## EMI CONSIDERATIONS

To meet various conducted line emission standards, additional Y-capacitors may be needed to attenuate common-mode noise. SynQor recommends that safety-rated ceramic capacitors be placed across any isolated DC-DC converters on the output of the PFC from Vin- to Vout- and Vout- to ground. However, the total capacitance from the PFC output leads to earth ground should not be more than 20nF if one of the PFC input leads is connected to earth ground. See “Typical Application of the PFC Module” (Figure A) for a diagram and suggested parts.

## PARALLELING MULTIPLE PFCQORS

In higher power applications, multiple units can be used in parallel as shown below.

- To balance load currents evenly between PFCQor modules, a 0.1 ohm resistor must be placed in series with Vout- on each module. The parallel diagram below shows correct placement of the resistors in relation to other circuitry. Resistors must be rated to handle RMS load return current.
- $\overline{PFC\_ENABLE}$  may be driven with a common signal, but a 100 ohm resistor should be placed in series with each input before being connected to the common node.
- AUX Bias outputs can be directly connected together as shown.
- $\overline{AC\_GOOD}$  can drive a common signal, but a 100 ohm resistor should be placed in series with each output before being connected to the common node.
- The loads should only be enabled when all the individual  $\overline{LOAD\_ENABLE}$  outputs have been asserted low. The circuit shown below combines the individual  $\overline{LOAD\_ENABLE}$  outputs into a single master  $\overline{LOAD\_ENABLE}$  to achieve this requirement.
- Active current sharing is accomplished by connecting all IMON pins directly together. The voltage at the IMON pins is then indicative of the average output current. Again, any circuit used to monitor the IMON voltage should have high input impedance.

## PARALLEL DIAGRAM

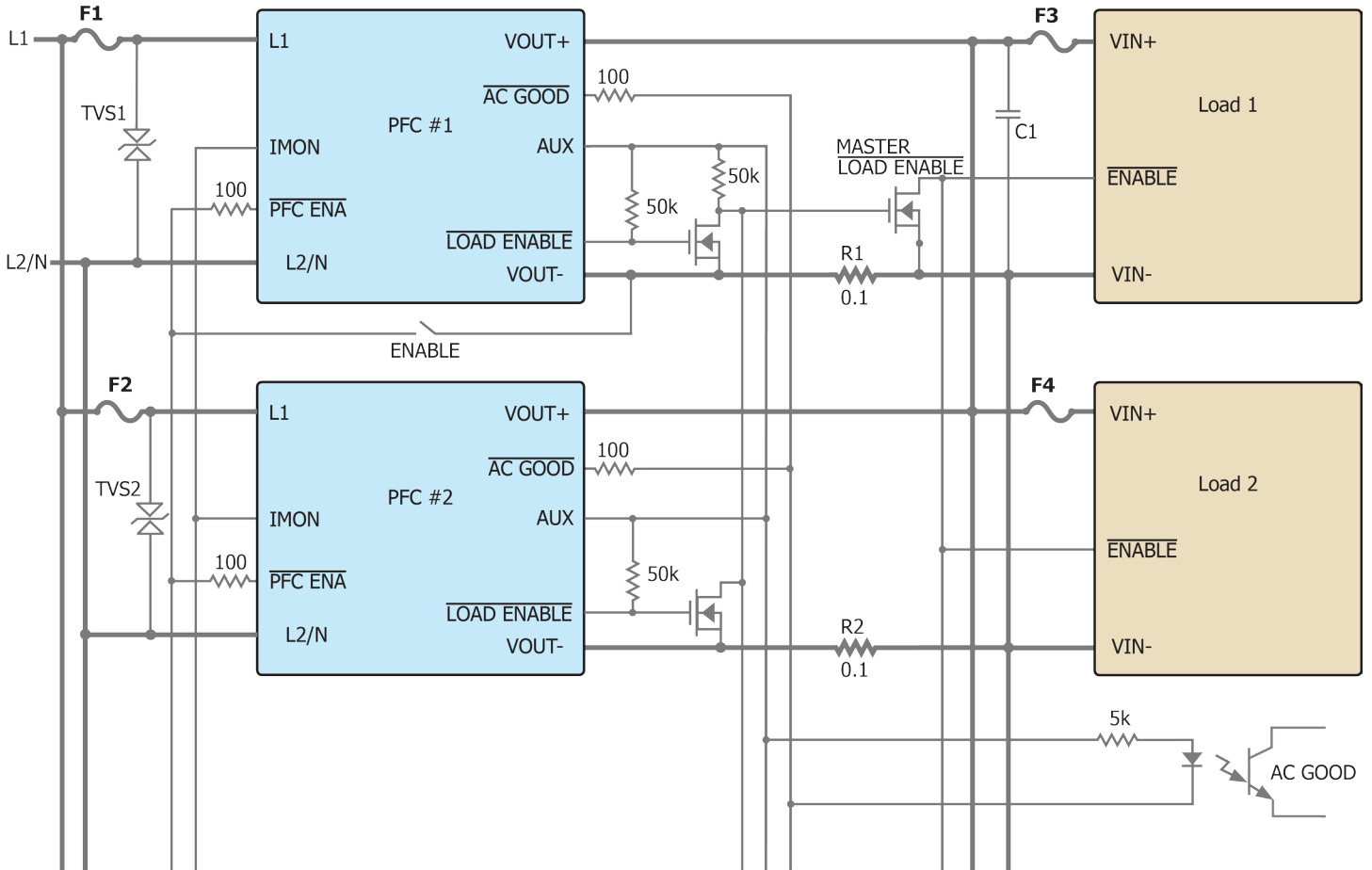

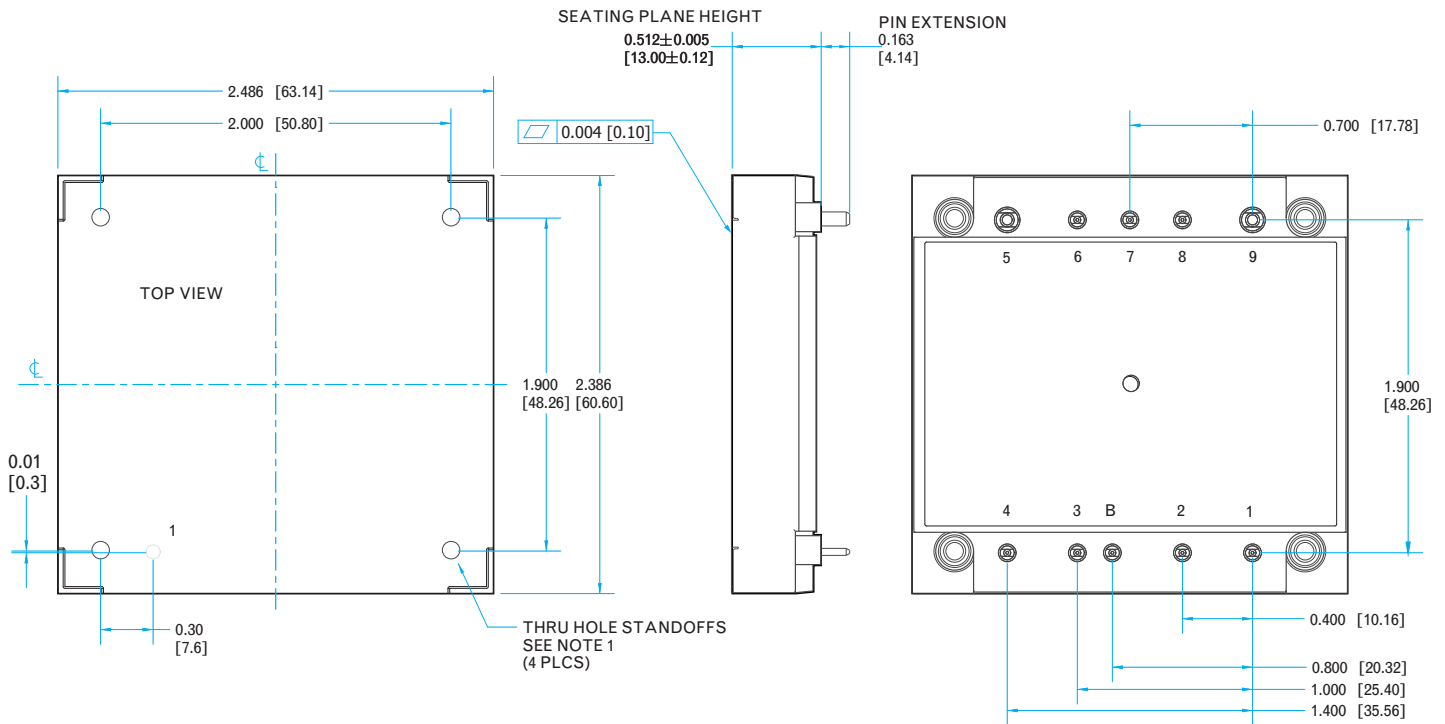

### NOTES

- Applied torque per screw should not exceed 6in-lb. (0.7 Nm).
- Baseplate flatness tolerance is 0.004" (.10 mm) TIR for surface.
- Pins 1-4, 6-8, and B are 0.040" (1.02mm) diameter, with 0.080" (2.03mm) diameter standoff shoulders.
- Pins 5 and 9 are 0.080" (2.03 mm) diameter with 0.125" (3.18 mm) diameter standoff shoulders.
- All Pins: Material - Copper Alloy; Finish - Matte Tin over Nickel plate
- Undimensioned components are shown for visual reference only.
- Weight: 4.9 oz (139 g)
- Threaded and Non-Threaded options available
- All dimensions in inches (mm).
- Tolerances:
  - x.xx +/-0.02 in. (x.x +/-0.5mm)
  - x.xxx +/-0.010 in. (x.xx +/-0.25mm)
  - unless otherwise noted.
- Workmanship: Meets or exceeds IPC-A-610C Class II

### PIN DESIGNATIONS

Pin	Name	Function
1	L1	AC Line 1
2	CLK SYNC	Clock Synchronization Input
B	IMON	Output Current Monitor / Current Share
3	PFC ENA	Negative Logic PFC Enable
4	L2/N	AC Line 2 / Neutral
5	-VOUT	Negative Output Voltage
6	AUX	Auxiliary Bias power supply
7	LOAD ENA	Negative Logic load enable and power out good signal
8	AC GOOD	Negative Logic AC Good signal
9	+VOUT	Positive Output voltage

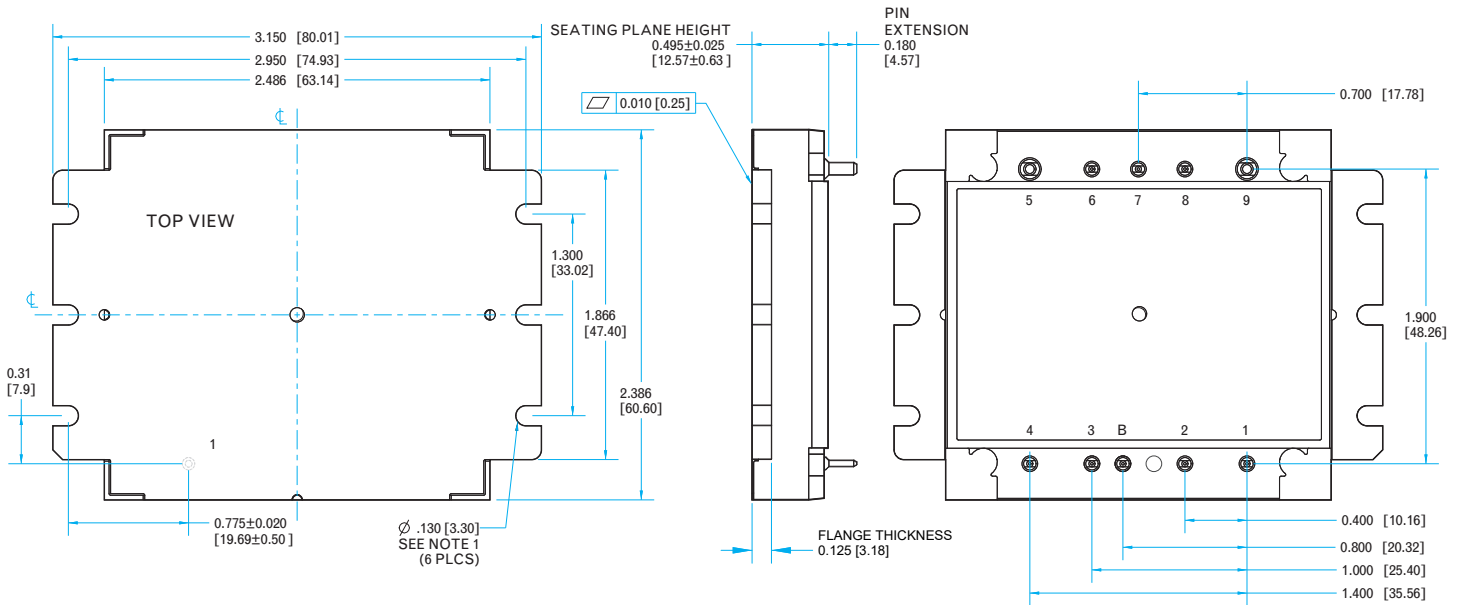

### NOTES

- 1) Applied torque per M3 or 4-40 screw should not exceed 6in-lb. (0.7 Nm).
- 2) Baseplate flatness tolerance is 0.010" (.2mm) TIR for surface.
- 3) Pins 1-4, 6-8, and B are 0.040" (1.02mm) diameter, with 0.080" (2.03mm) diameter standoff shoulders.
- 4) Pins 5 and 9 are 0.080" (2.03 mm) diameter with 0.125" (3.18 mm) diameter standoff shoulders.
- 5) Other Pin extensions lengths available
- 6) All Pins: Material - Copper Alloy; Finish - Matte Tin over Nickel plate
- 7) Undimensioned components are shown for visual reference only.
- 8) Weight: 5.1 oz (145 g)
- 9) All dimensions in inches (mm).

#### Tolerances:

- x.xx +/-0.02 in. (x.x +/-0.5mm)
- x.xxx +/-0.010 in. (x.xx +/-0.25mm)
- unless otherwise noted.

- 10) Workmanship: Meets or exceeds IPC-A-610C Class II

### PIN DESIGNATIONS

Pin	Name	Function
1	L1	AC Line 1
2	CLK SYNC	Clock Synchronization Input
B	IMON	Output Current Monitor / Current Share
3	PFC ENA	Negative Logic PFC Enable
4	L2/N	AC Line 2 / Neutral
5	-VOUT	Negative Output Voltage
6	AUX	Auxiliary Bias power supply
7	LOAD ENA	Negative Logic load enable and power out good signal
8	AC GOOD	Negative Logic AC Good signal
9	+VOUT	Positive Output voltage



# Ordering Information

**PFCU390HPx07**

**Input: 100-240Vrms**

**Output: 390Vdc**

**Power: Up to 700W**

Part Numbering Scheme									
Family	Input Voltage Range	Output Voltage	Package Size	Performance Level	Thermal Design	Output Power	Input Phases	Pin Style	Parallel Capability
PFC	U: 85-264 Vrms	390: 390V	H: Half-brick	P: Peta	<b>C:</b> Encased <b>D:</b> Encased with Non-threaded Baseplate <b>V:</b> Encased with Flanged Baseplate	07: 700W	S: Single-Phase	R: 0.180"	S: Supports Parallel Capability

## PART NUMBERING SYSTEM

The part numbering system for SynQor's dc-dc converters follows the format shown in the example below.

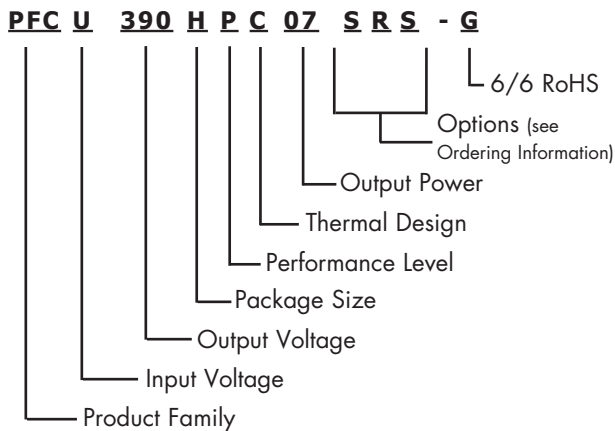

The first 12 characters comprise the base part number and the last 3 characters indicate available options. The "-G" suffix indicates 6/6 RoHS compliance.

## ORDERING INFORMATION

The tables below show the valid model numbers and ordering options for converters in this product family. When ordering SynQor converters, please ensure that you use the complete 15 character part number consisting of the 12 character base part number and the additional characters for options. InQor units are only available with 6/6 RoHS compliance indicated by "-G".

The following options must be included in place of the **wxyz** spaces in the model numbers listed above.

Not all combinations make valid part numbers, please contact SynQor for availability.

## Application Notes

A variety of application notes and technical white papers can be downloaded in pdf format from our [website](#).

**RoHS Compliance:** The EU led RoHS (Restriction of Hazardous Substances) Directive bans the use of Lead, Cadmium, Hexavalent Chromium, Mercury, Polybrominated Biphenyls (PBB), and Polybrominated Diphenyl Ether (PBDE) in Electrical and Electronic Equipment. This SynQor product is 6/6 RoHS compliant. For more information please refer to SynQor's RoHS addendum available at our [RoHS Compliance / Lead Free Initiative web page](#) or e-mail us at [rohs@synqor.com](mailto:rohs@synqor.com).

## Contact SynQor for further information and to order:

Phone: 978-849-0600 Fax: 978-849-0602

E-mail: [power@synqor.com](mailto:power@synqor.com) Web: [www.synqor.com](http://www.synqor.com)

Address: 155 Swanson Road, Boxborough, MA 01719 USA

## WARRANTY

SynQor offers a two (2) year limited warranty. Complete warranty information is listed on our website or is available upon request from SynQor.

## PATENTS

SynQor holds numerous U.S. patents, one or more of which apply to most of its power conversion products. Any that apply to the product(s) listed in this document are identified by markings on the product(s) or on internal components of the product(s) in accordance with U.S. patent laws. SynQor's patents include the following:

7,765,687 7,787,261  
8,149,597 8,644,027